

# D24-100

## LITHIUM-ION BATTERY PACKS



## FUNCTIONAL DESCRIPTION

Battery Contacts

Release Buttons

Fuel Gauge

Fuel Gauge Button



# SPECIFICATIONS

## D24-100

Rated Power	98Wh
Rated Voltage	24.5V
Rated Capacity	4.0Ah
Working Temperature	-10~50 °C
Working Humidity	20~98%
Battery Cycle Life	1000 times
Dimension	113x102x101mm
Weight	0.9kg

## Size (mm)

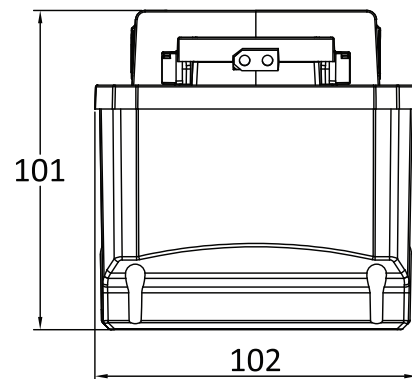
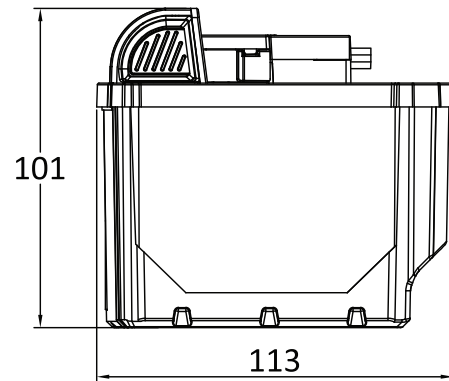

## Package

Size of Box	115X125X120mm
Gross Weight	1.0kg
Size of Carton	380x370x160mm
Gross Weight	9.0kg
Box Quantity/Carton	9Pcs

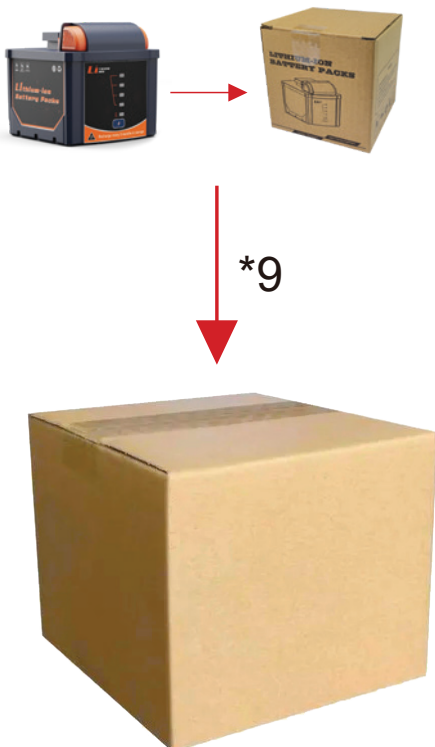

## POWER DISPLAY

